

# AGP™ PELLET STOVE & INSERT





# EASY TO LIVE WITH...

## WHY DO WE CALL IT THE AGP?



Designed to burn all grades of wood pellets

AGP stands for "ALL GRADES OF PELLETS". We've designed the AGP freestanding stove and insert to efficiently and effectively burn all grades of wood pellet fuel. The AGP is easy to own, easy to operate, and easy to live with! Heavy duty construction, innovative technology, and premium features combine to bring you a reliable and efficient home heater that will keep your family warm for years to come!

### **EPA Certified Emissions and Efficiency**

Emissions: STOVE - 1.8 Grams/Hr\*    INSERT - 0.98 Gram/Hr\*

Maximum Efficiency: 75.6%

*\*This model was tested for efficiency using method B415.1-10 and was determined to have a weighted average higher heating Value (HHV) Overall Heating Efficiency (OHE) of 75.6%.*



HRD Feed System

The AGP's advanced fuel delivery system features unique components and next generation technology that eliminates many of the maintenance headaches previously associated with owning a pellet stove or insert. NO burn backs, ensures safe operation

### **Horizontal Rotary Disc (HRD):**

- Controls the amount of fuel that leaves the hopper and enters the auger
- Delivers a precise amount of fuel and eliminates any chance of burn backs

### **Horizontal Auger:**

- Moves the fuel from the drop zone to the inclined platform. By being horizontal it offers two distinct advantages:
  1. Along with the pellets, it moves the pellet fines onto the burn platform to be burned, instead of causing a potential maintenance issue (MORE HEAT, LESS WASTE)
  2. Less stress on the auger motor = longer life with years of smooth, quiet operation



Stainless Steel Burn Platform

### **Burn Platform:**

- This is where intense combustion occurs
- The heavy-duty burn platform is made from high-grade 304 stainless steel that is 3/16" thick
- The inclined floor of the burn platform is at a 14 degree angle and is self-tuned to burn the fuel completely.



Watch a video on how the HRD works

# EASY TO OWN!



1. Large Capacity Hopper
2. Horizontal Rotary Disc (HRD)  
Feed with Case Hardened,  
Replaceable Shear Blade
3. Drive Motor for HRD
4. Pellet Holding Chamber
5. Fire Chamber
6. Primary Fuel Feed Push Auger
7. Drive Motor for Auger
8. Stainless Steel Burn Platform
9. Ash Pan
10. Combustion Fan
11. Negative Pressure Flow Switch
12. Outside Combustion Air
13. Combustion Air Restrictor
14. (a) Airwash (Bottom)
14. (b) Airwash (Top)
15. Ceramic Glass Door
16. External Heat Exchange Tubes
17. 3" Exhaust
18. Easy to Use Control Panel
19. High Heat Transfer Convection Fan (*Not shown*)

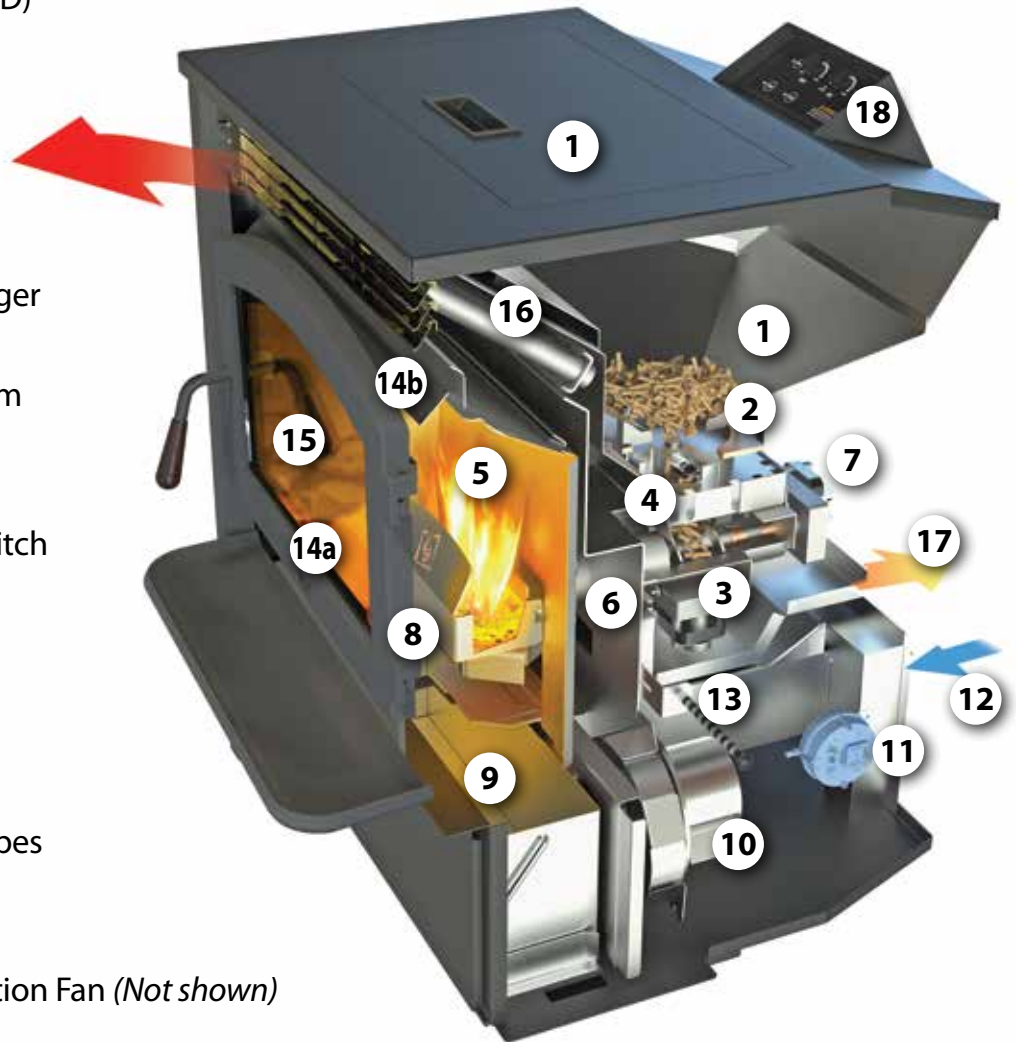

## STATE-OF-THE-ART CONTROL PANEL



Control Panel on AGP Stove

\* Combines the heat and fan functions to operate together. Simply turn the fan control all the way to the left until the BLUE "Auto Fan" light illuminates.

Seven control functions and features:

- |                 |  |
|-----------------|--|
| 1. Start Button | - Starts the units   |
| 2. Stop Button  | - Stops the units  |
| 3. Heat Control | - Adjust the heat output from low to high. 1.4 lbs. – 5 lbs. per hour      |
| 4. Fan Control* | - Adjust the room air fan to move air through the units and into the home. |
| 5. Thermostat   | - Allows the units to be controlled by a remote thermostat.                |
| 6. LED Light    | - Illuminates panel for easy reading of controls. AGP Insert only.         |
| 7. System Fuse  | - Easy access to replace the fuse if needed. AGP Insert only.              |



Control Panel on AGP Insert

# AGP™ PELLET STOVE



***EPA Certified  
Only 1.8 Grams/Hour***

Homeowners Video



<u>Hopper Capacity</u> 80 lbs.	<u>Heating Capacity*</u> 800 to 2,000 Sq. Ft.	<u>Burn Times</u> Low - 57 Hrs High - 16 Hrs	<u>Turn Down Ratio</u> 71%	<u>Btu/Hour Range**</u> Low - 11,480 High - 41,000	<u>Burn Rate Per Hour</u> Low - 1.4 lbs High - 5 lbs	<u>Glass Area</u> 127 Sq. In.
-----------------------------------	---	--	-------------------------------	--	--	----------------------------------

\* HEATING CAPACITY may vary depending on the degree of home insulation, floor plan and ambient temperature zone of the area in which you live. BTU/Hour range will vary with the quality, size and brand of pellets used.

\*\* Based on 8,200 BTUs per pound.

# AGP STOVE

The AGP Stove offers all the benefits of wood heating plus fuel that is clean, compact and easy to use. This freestanding stove is ideal for heating any medium or large living space, giving off a radiant warmth up to 2,000 square feet. The roaring flames are surrounded by a beautiful arched door that presents a timeless look and will complement any personal style. The fire viewing area features a super-efficient airwash system to keep the glass clean. With a large, easily removable ash pan and 80 lb. hopper capacity, this stove has the ability to produce extremely long burn times, up to 57 hours when burning on a low setting.

**Straight -Through The Wall Installation**

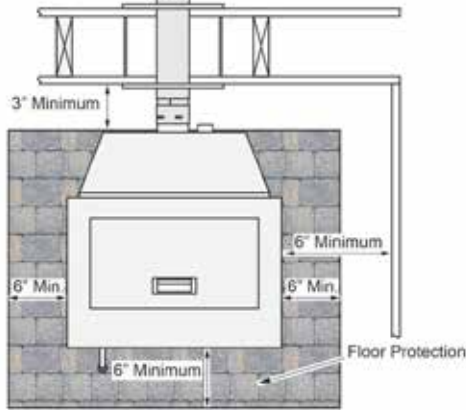

**Interior Vertical Vent Installation**

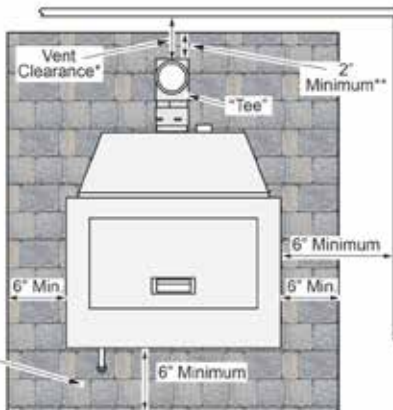

## MINIMUM CLEARANCES TO COMBUSTIBLE WALLS

Stove clearances measured from top of stove. Connector clearances measured from exhaust vent.

## FLOOR PROTECTION

The heater must be installed on a non-combustible floor protector extending the full width and depth of the heater and extending 6" (153mm) in front and sides of fuel loading or ash removal doors (minimum .018" thick - 26 gauge).

**Corner - Through The Wall Installation**

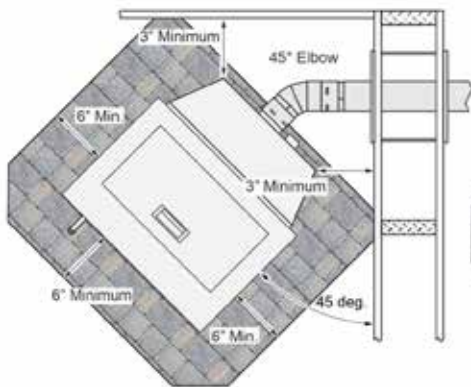

**Interior Vertical Vent Installation**

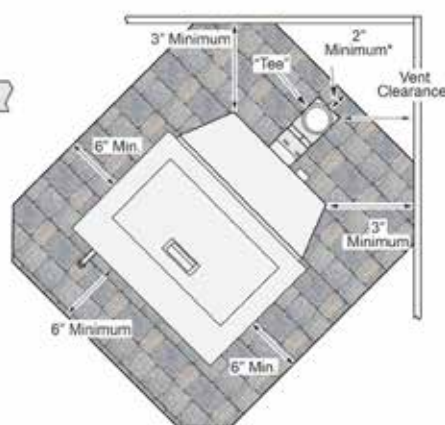

## ALCOVE REQUIREMENTS

When installed in an alcove with a ceiling height less than 7 ft (2.134 M).

- Minimum Height is 60" with 6" side and 3" rear clearance to wall.
- Minimum Width is 36-9/16" with min. clearance of 3" for horizontal venting.
- Maximum depth is 48" with minimum clearance of 2" from pipe for vertical venting.

## STOVE DIMENSIONS

3" (77mm) Dia. Exhaust  
(centered on appliance)

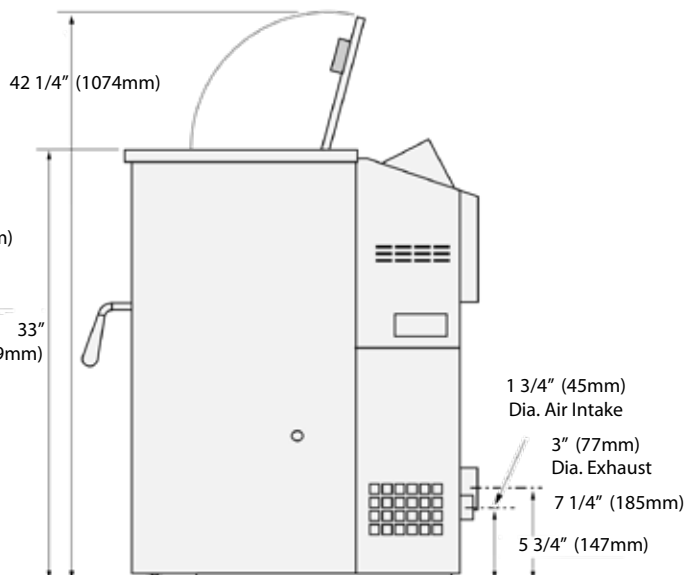
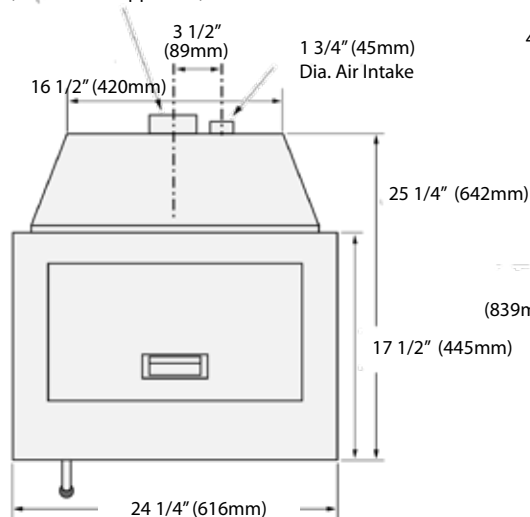

# AGP™ PELLET INSERT



***EPA Certified  
Only 0.98 Grams/Hour***

Homeowners Video



Adjustable Hopper	Heating Capacity**	Burn Times*	High to Low Turn Down*	Btu/Hour Range***	Burn Rate Per Hour*	Glass Area
40 to 70 lbs.	800 to 2,000 Sq. Ft.	Low - 50 Hrs High - 28 Hrs	71%	Low - 11,480 High - 41,000	Low - 1.4 lbs High - 5 lbs	127 Sq. In.

\*\* HEATING CAPACITY may vary depending on the degree of home insulation, floor plan and ambient temperature zone of the area in which you live.  
BTU/Hour range, Turn down ratio and burn times will vary with the quality, size and brand of pellets used. Burn times based on 70 lb. fuel load.

\*\*\* Based on 8,200 BTUs per pound.

# AGP INSERT

The AGP Insert employs the same innovative technology as the freestanding AGP Stove, but is ideal for converting an inefficient, open fireplace into a beautiful source of heat for your home. This environmentally sound way to heat your home produces less than one gram of emissions per hour and burns ALL GRADES of wood pellets. This low maintenance insert comes standard with an easy removal ash pan for simple cleanup. Up to 70 lbs. of pellets can be loaded into the large capacity hopper at once, giving you longer burns and more time to enjoy the fire.

## MINIMUM FIREPLACE CLEARANCES

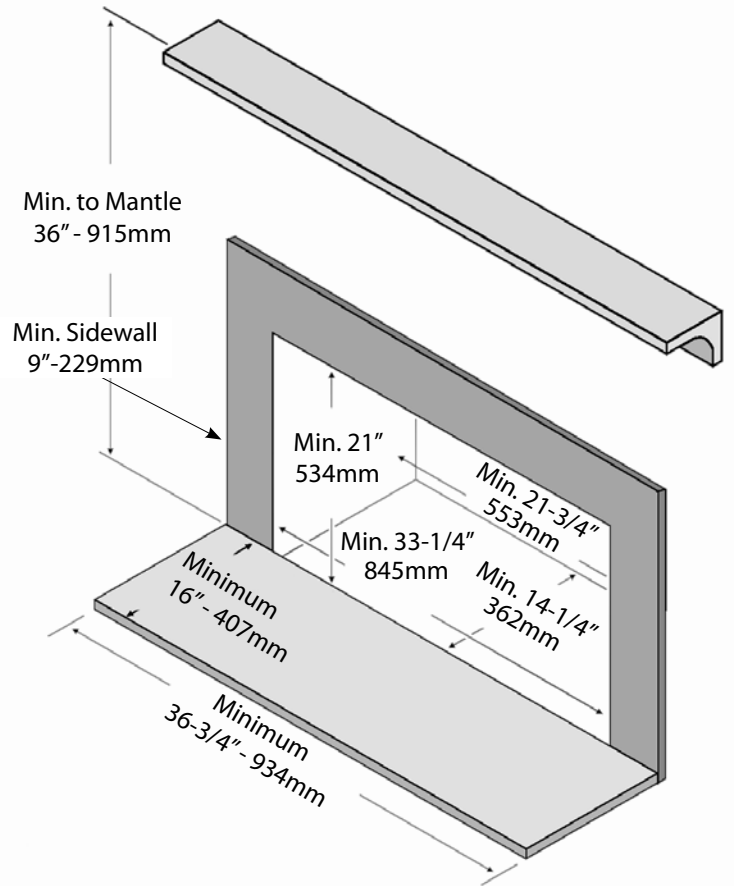

## FLOOR PROTECTION

The pellet insert must be installed on a non-combustible surface. A non-combustible hearth must extend 6" to the front and sides of the firebox opening.

Hearth protection must be a minimum .018" thick (26 gauge).

## INSERT DIMENSIONS

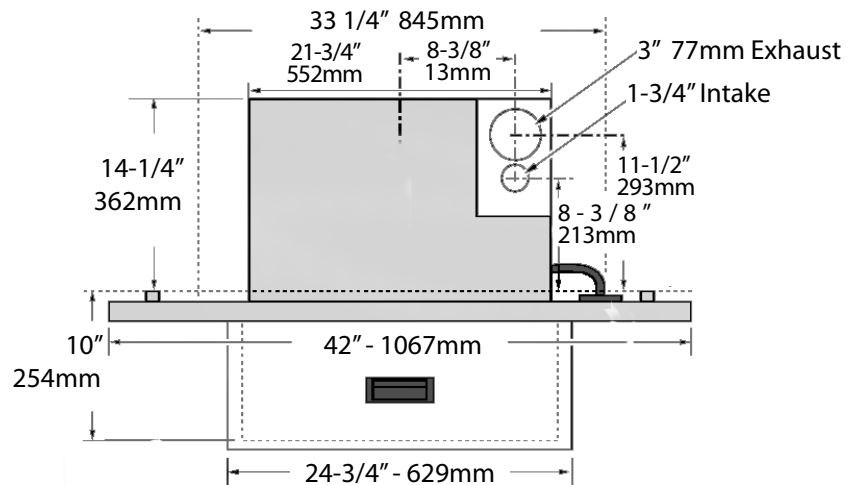
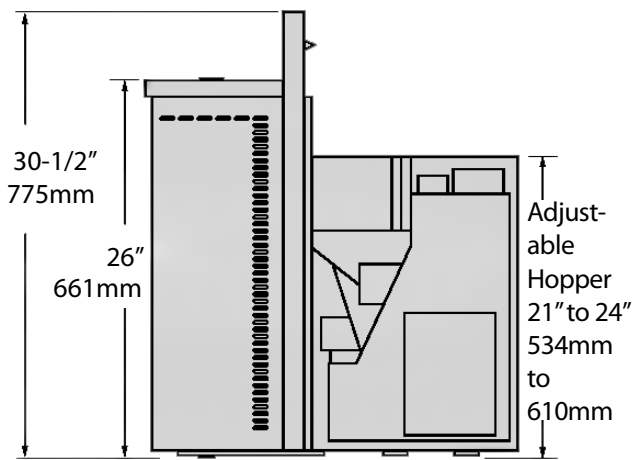



## SAFETY

If you have small children or pets at home, we recommend installing a safety screen or guard to prevent accidental contact with the hot surfaces of the appliance.

## TESTING

Listed Pelletized Solid Fuel Burning Appliance. Also for use in mobile homes. Certified for the US and Canada.

Conforms to ASTM E1509-04, Room Heater Pellet Burning Type (UM) 84 HUD; Certified to ULC S627. Tested and listed for mobile homes in accordance with OAR 814-23-900 through 814-23-909. Tested and Listed by Intertek.

## ELECTRICAL SPECIFICATIONS

Electrical Rating.....115 Volts, 3 Amps, 60 Hz

Watts during Start-Up Sequence..... 350 (approximately)

Watts during Operation..... 250 (approximately)

Use the installation illustrations as a guide only. For complete installation instructions please refer to your Lopi Dealer or go to the AGP Pellet Insert product page at [www.LopiStoves.com](http://www.LopiStoves.com).

**NOTE:** Improper installation of your pellet appliance or failure to operate it in accordance to the guidelines detailed in the Owner's Manual may negate your warranty and endanger your home and family.

### YOUR LOPI AUTHORIZED DEALER:



Manufactured by  
Travis Industries, Inc.  
Mukilteo, WA  
[www.lopistoves.com](http://www.lopistoves.com)



©2026/01 Printed in U.S.A. - #98800724

Lopi reserves the right to alter or improve its products at any time without notification. All trademarks belong to Travis Industries. For installation specifications refer to the Owner's Manual found on the Lopi website. U.S. and Foreign Patents Pending.